

NTN®

Cylindrical Roller Bearings

ULTAGE



ULTAGE

CAT. No. 3037-II/E

Rating life

+80% (max.)

Basic dynamic load rating

+20% (max.)

Allowable speed

+20% (max.)

ULTAGE

Cylindrical Roller Bearings ULTAGE Series

Cylindrical roller bearings of ULTAGE series are new standard series of NTN bearings and deliver longer life, increase of load capability, and higher limiting speed required for any industrial machinery.

Higher Reliability

- Greater load capacity by optimizing internal specifications
- Longer maintenance interval

Increase of Load Capability

- Allowable misalignment 0.002rad (7')
- ※ Under conditions of $F_r \leq 0.20C_r$

Higher Limiting Speed

- max. 20% increase of allowable speed by optimizing internal specifications
- ※ With oil lubrication

Cage

- Resin cage
- Roller guided type

Inner ring

Outer ring

Rollers

- Larger diameter rollers
- Optimized crowning

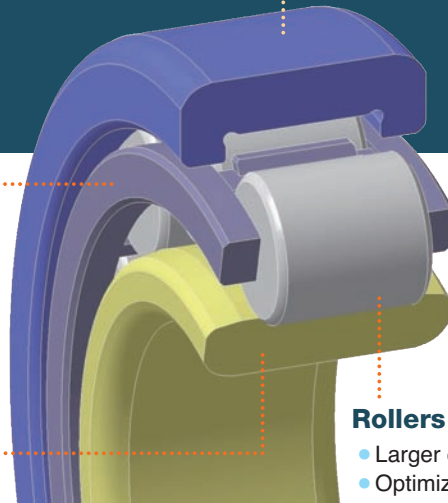

Features

1. World's highest level load carrying capacity

Higher load carrying capacity and longer rating life by optimizing internal specifications

- (1) Rating life : max. +80% (compared to conventional NTN E type)
- (2) Basic dynamic load rating : max. +20% (compared to conventional NTN E type)

2. Allowable misalignment (see Fig. 1)

Allowable misalignment : 0.002rad (7')

Optimized crowning allows combination of $0.20C_r$ and misalignment up to 0.002rad (7', 1/500) to be used. When the radial load exceeds $0.20C_r$, please ask NTN. *Minimum required load: $0.04C_{0r}$. C_r means basic dynamic load rating, and C_{0r} means basic static load rating listed in this catalogue.

3. Allowable speed

max. +20% with oil lubrication (compared to conventional NTN E type)

4. Adopted resin cage as standard (see Fig. 2)

- (1) Standard use of integrated polyamide resin cage results in higher limiting speed and longer life of grease.
- (2) Resin cage material: polyamide reinforced with glass fiber.
※ If machined cage for high speed is required, please ask NTN.

5. Interchangeability

Boundary dimensions comply with ISO 15, JIS B 1533, DIN 5412, and the dimensions of these bearings are also same as conventional NTN E type.

6. Allowable axial load

Same as conventional NTN E type.

7. Allowable temperature

Allowable temperature of bearings : 120°C

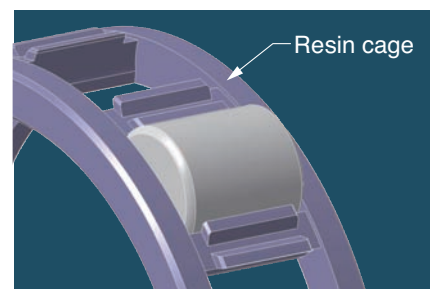
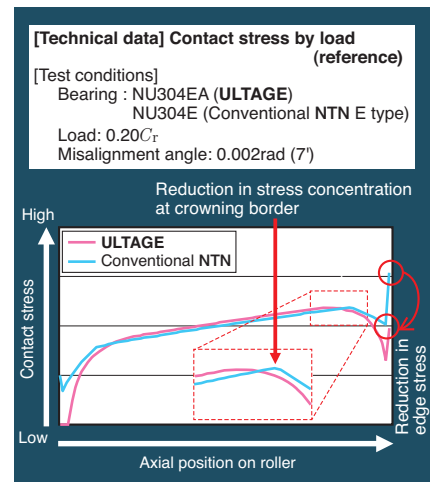

"ULTAGE" (a name created from combination of "Ultimate", signifying refinement, and "Stage", signifying NTN's intention that this series of products be employed in diverse applications) is the general name for NTN's new generation of bearings that are noted for their industry-leading performance.

Allowable axial load

Cylindrical roller bearings with ribs on the inner and outer rings are capable of simultaneously bearing a radial load and an axial load of a certain degree. Unlike basic load ratings based on rolling fatigue, allowable axial load is determined by heat produced on the sliding surface between the ends of the rollers and rib, seizure and wear. Allowable axial load when center axial load is applied is approximately determined by formula (1), which is based upon experience and testing.

$$P_t = k \cdot d^2 \cdot P_z \dots\dots\dots (1)$$

Where :

- P_t : Allowable axial load when rotating N
- k : Factor determined by internal design of bearing (see **Table 1**)
- d : Bearing bore mm
- P_z : Allowable surface pressure of rib MPa (see **Fig. 3**)

If axial load is greater than radial load, the rollers will not rotate properly. The allowable axial load therefore must not exceed the value for $F_{a \max}$ given in **Table 1**.

The following are also important to operate the bearing smoothly under axial load:

- (1) Do not make the internal radial clearance any larger than necessary.
- (2) Use lubricant with extreme pressure additive.
- (3) Make the shoulder of the housing and shaft high enough for the rib of the bearing.
- (4) If the bearing is to support an extreme axial load, mounting precision should be improved and the bearing should rotate slowly before actual use.

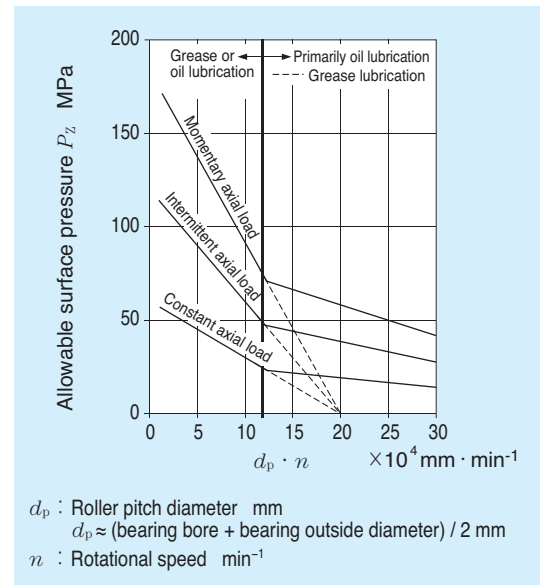

Fig.3 Allowable surface pressure of rib

Table 1 Factor k values and allowable axial loads ($F_{a \max}$)

Bearing series	k	$F_{a \max}$
NJ, NUP, NH2EA	0.050	$0.4F_r$
NJ, NUP, NH22EA		
NJ, NUP, NH3EA	0.080	$0.4F_r$
NJ, NUP, NH23EA		

Allowable speed

Higher bearing speeds result in higher bearing temperatures caused by friction. When the bearing temperature exceeds a specific limit, the lubricant performance deteriorates significantly, leading to abnormally high temperature and bearing seizure.

The factors that affect the allowable bearing speed include the followings:

- (1) Bearing type
- (2) Bearing size
- (3) Lubrication system (grease, circulating lubrication, oil bath, etc.)
- (4) Bearing internal clearance (internal clearance of running bearing)
- (5) Bearing load
- (6) Dimensional accuracy with shaft, housing, etc.

The allowable speeds indicated in the bearing dimension table are for reference only and apply only when bearings are lubricated and heat is efficiently drawn away from the bearing.

The allowable speeds in this catalogue are categorized as follows:

[Oil-lubricated bearings]

The bearing speed at which the outer ring temperature reaches 80°C when the bearing is allowed to run at 5% basic static load rating C_{0r} while lubricated with oil (viscosity VG32) which is assimilated to room temperature and fed at a rate of 1 liter/min (circulating lubrication)

[Grease-lubricated bearings]

The bearing speed at which the outer ring temperature reaches 80°C when the bearing, which has undergone running-in operation, is allowed to run at 5% basic static load rating C_{0r} with the bearing's internal free volume 20 to 30% pre-filled with lithium grease (consistency: NLGI3)

With either lubrication system, the bearing temperature rise profile varies with the operating conditions (operating load, running speed pattern, lubricating conditions, etc.) in which the bearing is used. Therefore, select the optimal bearing by allowing sufficient margin for the allowable speed for that particular bearing as indicated in the catalogue.

Contact **NTN** for technical assistance if the bearing speed in the intended application exceeds 80% of the allowable speed indicated in the bearing dimension table, or if the intended bearing is to be used under severe operating conditions involving vibration and impact.

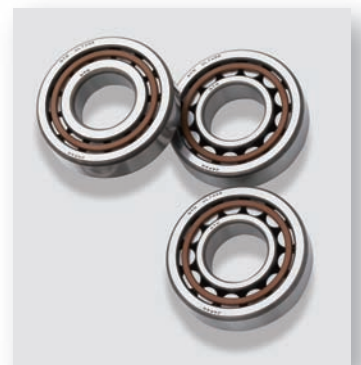

Allowable misalignment

Allowable misalignment : 0.002 rad (7') or less

* Under conditions of : $F_r \leq 0.20C_r$ C_r means basic dynamic load rating listed in this catalogue.

Bearing number

NU 22 04 EA T2X C3

- Radial internal clearance: C3
- Cage code : resin cage
- Type code : ULTAGE**
- Nominal bore diameter: 20 mm
- Dimension series: 22
- Bearing series : cylindrical roller bearing NU type

* Suffix "U" is added at the end of bearing number for NUP type.

Bearing series

Components of NU type

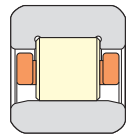

- Outer ring (with double ribs)
- Rollers
- Cage
- Inner ring

Assembly of outer ring, rollers and cage can be separated from inner ring.

Components of NJ type

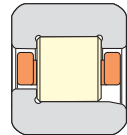

- Outer ring (with double ribs)
- Rollers
- Cage
- Inner ring (with single rib)

Assembly of outer ring, rollers and cage can be separated from inner ring.

Components of NUP type

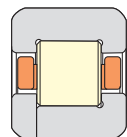

- Outer ring (with double ribs)
- Rollers
- Cage
- Inner ring (with single-rib)
- Inner ring collar ring

Assembly of outer ring, rollers and cage can be separated from inner ring and collar ring.

Accuracy

Table 2 Inner rings

Nominal bore diameter d mm	over	incl.	Dimensional tolerance of mean bore diameter within plane Δd_{mp}				Bore diameter variation within plane V_{dsp}		Mean bore diameter variation V_{dmp}		Inner ring radial runout K_{ia}		Inner ring width deviation ΔB_s		Inner ring width variation V_{Bs}	
			class 0		class 6		class 0	class 6	class 0	class 6	class 0	class 6	class 0	class 6	class 0	class 6
			high	low	high	low	max	max	max	max	max	max	max	max	max	max
18	30	0	-10	0	-8	8	6	8	6	13	8	0	-120	20		
30	50	0	-12	0	-10	9	8	9	8	15	10	0	-120	20		
50	80	0	-15	0	-12	11	9	11	9	20	10	0	-150	25		
80	120	0	-20	0	-15	15	11	15	11	25	13	0	-200	25		

Unit : μm

Table 3 Outer rings

Nominal outside diameter D mm	over	incl.	Dimensional tolerance of mean outside diameter within plane ΔD_{mp}				Outside diameter variation within plane V_{Dsp}		Mean outside diameter variation V_{Dmp}		Outer ring radial runout K_{ea}		Outer ring width deviation ΔC_s all type		Outer ring width variation V_{Cs}	
			class 0		class 6		class 0	class 6	class 0	class 6	class 0	class 6	class 0, class 6		class 0, class 6	
			high	low	high	low	max	max	max	max	max	max	max	max	max	
30	50	0	-11	0	-9	8	7	8	7	20	10	Depends on tolerance of ΔB_s in relation to d of same bearing	Depends on tolerance of V_{Bs} in relation to d of same bearing			
50	80	0	-13	0	-11	10	8	10	8	25	13					
80	120	0	-15	0	-13	11	10	11	10	35	18					
120	150	0	-18	0	-15	14	11	14	11	40	20					
150	180	0	-25	0	-18	19	14	19	14	45	23					

Unit : μm

Chamfer measurements

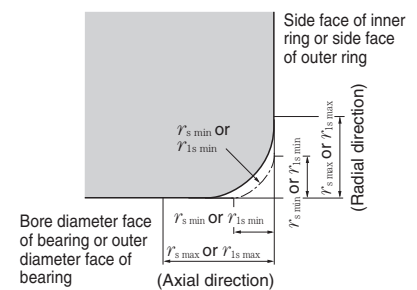

Table 4 Allowable critical-value of bearing chamfer

$r_s \text{ min}^{(1)}$ or $r_{1s \text{ min}}$	Nominal bore diameter d		$r_s \text{ max}$ or $r_{1s \text{ max}}$	
	over	incl.	Radial direction	Axial direction
0.6	—	40	1	2
1	—	50	1.5	3
1.1	—	120	2	3.5
1.5	—	120	2.3	4
2	—	80	3	4.5
	80	220	3.5	5
2.1	—	280	4	6.5

Unit : mm

Note 1) These are the allowable minimum dimensions of the chamfer dimension " r_s " or " r_{1s} " and are described in the dimensional table.

Radial internal clearance

Table 5 Interchangeable radial internal clearance

Nominal bore diameter d mm	over	incl.	Unit : μm									
			C2		(CN) ¹⁾		C3		C4		C5	
			min	max	min	max	min	max	min	max	min	max
10	24	0	25	20	45	35	60	50	75	65	90	
24	30	0	25	20	45	35	60	50	75	70	95	
30	40	5	30	25	50	45	70	60	85	80	105	
40	50	5	35	30	60	50	80	70	100	95	125	
50	65	10	40	40	70	60	90	80	110	110	140	
65	80	10	45	40	75	65	100	90	125	130	165	
80	100	15	50	50	85	75	110	105	140	155	190	

Table 6 Radial internal clearance for electric motor

Nominal bore diameter d mm	over	incl.	Unit : μm	
			CM ²⁾	
			min	max
24	30	15	30	
30	40	15	30	
40	50	20	35	
50	65	25	40	
65	80	30	45	
80	100	35	55	

Table 7 Non-interchangeable radial internal clearance

Nominal bore diameter d mm	over	incl.	Unit : μm											
			C1NA		C2NA		NA ³⁾		C3NA		C4NA		C5NA	
			min	max	min	max	min	max	min	max	min	max	min	max
18	24	5	10	10	20	20	30	35	45	45	55	65	75	
24	30	5	10	10	25	25	35	40	50	50	60	70	80	
30	40	5	12	12	25	25	40	45	55	55	70	80	95	
40	50	5	15	15	30	30	45	50	65	65	80	95	110	
50	65	5	15	15	35	35	50	55	75	75	90	110	130	
65	80	10	20	20	40	40	60	70	90	90	110	130	150	
80	100	10	25	25	45	45	70	80	105	105	125	155	180	

Note 1) "CN" is not indicated on bearing number
 2) Non-interchangeable clearance
 3) For bearings with normal clearance, only NA is added to bearing numbers.
 Example: NU310EAT2XNA

Bearing Fits

General standards of bearing fits for each condition of use are shown in **Table 8** to **Table 10**.

Table 8 Tolerance class of shafts commonly used for cylindrical roller bearings (classes 0 and 6)

Conditions		Shaft diameter (mm)		Shaft tolerance class	Remarks
		over	incl.		
Inner ring rotational load or load of underrind direction	Light load ¹⁾ or fluctuating load	—	40	js6	When greater accuracy is required js5, k5, and m5 may be substituted for js6, k6, and m6.
		40	140	k6	
	Ordinary load ¹⁾	—	40	k5	—
40		100	m5		
Inner ring static load	Inner ring must move easily over shaft	Overall shaft diameter		g6	When greater accuracy is required use g5. For large bearings, f6 will suffice for to facilitate movement.
	Inner does not have to move easily over shaft	Overall shaft diameter		h6	When greater accuracy is required use h5.
Center axial load		Overall shaft diameter		js6	Generally, shaft and inner rings are not fixed using interference.

Note All values and fits listed in the above tables are for solid steel shafts.

Table 9 Tolerance class of housing bore commonly used for cylindrical roller bearings (classes 0 and 6)

Conditions			Tolerance class of housing bore	Remarks	
Housing	Types of load	Outer ring axial direction movement ²⁾			
Single housing or split housing	Outer ring static load	All types of loads	Yes	H7	G7 can be used for large bearings or bearings with large temperature differential between the outer ring and housing.
		Light load ¹⁾ or ordinary load ¹⁾	Yes	H8	—
		Shaft and inner ring become hot.	Easily	G7	F7 be used for large bearings or bearings with large temperature differential between the outer ring and housing.
Single housing	Indeterminate load	Requires precise rotation under light or ordinary loads	As a rule, cannot move.	K6	Primarily applies to roller bearings.
		Requires low noise operation	Yes	JS6	Primarily applies to ball bearings.
		Light or ordinary load	Yes	JS7	If high accuracy is required, Js6 and K6 are used in place of Js7 and K7
	Ordinary load or heavy load ¹⁾	As a rule, cannot move.	K7		
	Outer ring rotational load	High impact load	No	M7	—
		Light or fluctuating load	No	M7	—
		Ordinary or heavy load	No	N7	Primarily applies to ball bearings.
Heavy load or large impact load with thin wall housing		No	P7	Primarily applies to roller bearings.	

Remarks • All values and fits listed in the above tables are for cast iron or steel housings.

• If only center axial load is applied of the bearings, select a tolerance class provides clearance for the outer ring in the axial direction.

Note 1) Standards for light loads, normal loads, and heavy loads

- Light loads : equivalent radial load $\leq 0.05C_R$
- Normal loads : $0.05C_R < \text{equivalent radial load} \leq 0.10C_R$
- Heavy loads : $0.10C_R < \text{equivalent radial load}$

2) Indicates whether or not outer ring axial movement is possible with non-separable type bearings.

Table 10 Fits for electric motor bearings

Bearing Type	Shaft fits		Housing fits	
	Shaft diameter mm over	Tolerance class	Housing bore diameter	Tolerance class
Cylindrical roller bearings	—	k5	All sizes	H6 or J6
	40	m6		160

Dimensions table

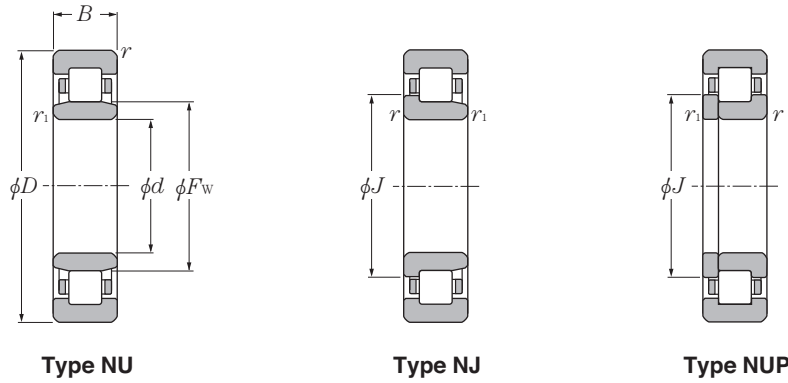

Boundary dimensions mm					Basic load ratings ²⁾				Limiting speeds ²⁾ min ⁻¹		Bearing numbers		
<i>d</i>	<i>D</i>	<i>B</i>	<i>r</i> _{s min¹⁾}	<i>r</i> _{1s min¹⁾}	dynamic kN	static kN	dynamic kgf	static kgf	grease	oil	Type NU	Type NJ	Type NUP
20	47	14	1	0.6	32.5	24.7	3 300	2 520	15 000	21 600	NU204EA	NJ	NUP
	47	18	1	0.6	38.5	31.0	3 950	3 150	14 000	19 200	NU2204EA	NJ	NUP
	52	15	1.1	0.6	37.5	26.9	3 800	2 740	13 000	18 000	NU304EA	NJ	NUP
	52	21	1.1	0.6	49.5	39.0	5 050	3 950	12 000	16 800	NU2304EA	NJ	NUP
25	52	15	1	0.6	34.5	27.7	3 550	2 830	13 000	18 000	NU205EA	NJ	NUP
	52	18	1	0.6	41.5	34.5	4 200	3 550	11 000	15 600	NU2205EA	NJ	NUP
	62	17	1.1	1.1	49.0	37.5	5 000	3 800	11 000	15 600	NU305EA	NJ	NUP
	62	24	1.1	1.1	67.5	56.0	6 850	5 700	9 700	13 200	NU2305EA	NJ	NUP
30	62	16	1	0.6	46.0	37.5	4 700	3 800	11 000	15 600	NU206EA	NJ	NUP
	62	20	1	0.6	58.0	50.0	5 900	5 100	9 700	13 200	NU2206EA	NJ	NUP
	72	19	1.1	1.1	63.0	50.0	6 400	5 100	9 300	13 200	NU306EA	NJ	NUP
	72	27	1.1	1.1	88.0	77.5	9 000	7 900	8 300	11 600	NU2306EA	NJ	NUP
35	72	17	1.1	0.6	59.5	50.0	6 050	5 100	9 500	13 200	NU207EA	NJ	NUP
	72	23	1.1	0.6	73.0	65.5	7 450	6 650	8 500	12 000	NU2207EA	NJ	NUP
	80	21	1.5	1.1	83.5	71.0	8 550	7 200	8 100	11 500	NU307EA	NJ	NUP
	80	31	1.5	1.1	117	109	11 900	11 100	7 200	10 200	NU2307EA	NJ	NUP
40	80	18	1.1	1.1	66.0	55.5	6 700	5 650	8 500	12 000	NU208EA	NJ	NUP
	80	23	1.1	1.1	85.5	77.5	8 700	7 900	7 600	10 700	NU2208EA	NJ	NUP
	90	23	1.5	1.5	98.5	81.5	10 000	8 300	7 200	10 200	NU308EA	NJ	NUP
	90	33	1.5	1.5	135	122	13 700	12 500	6 400	9 000	NU2308EA	NJ	NUP
45	85	19	1.1	1.1	74.5	66.5	7 600	6 800	7 600	10 800	NU209EA	NJ	NUP
	85	23	1.1	1.1	90.0	84.5	9 150	8 600	6 800	9 600	NU2209EA	NJ	NUP
	100	25	1.5	1.5	115	98.5	11 700	10 000	6 500	9 100	NU309EA	NJ	NUP
	100	36	1.5	1.5	162	153	16 600	15 600	5 700	8 200	NU2309EA	NJ	NUP
50	90	20	1.1	1.1	81.5	76.5	8 300	7 800	6 900	9 700	NU210EA	NJ	NUP
	90	23	1.1	1.1	98.5	97.0	10 000	9 900	6 200	8 800	NU2210EA	NJ	NUP
	110	27	2	2	130	113	13 300	11 500	5 900	8 300	NU310EA	NJ	NUP
	110	40	2	2	192	187	19 600	19 000	5 200	7 300	NU2310EA	NJ	NUP
55	100	21	1.5	1.1	102	98.5	10 400	10 100	6 300	8 900	NU211EA	NJ	NUP
	100	25	1.5	1.1	120	122	12 200	12 400	5 600	7 900	NU2211EA	NJ	NUP
	120	29	2	2	162	143	16 500	14 600	5 300	7 600	NU311EA	NJ	NUP
	120	43	2	2	238	233	24 200	23 800	4 700	6 700	NU2311EA	NJ	NUP
60	110	22	1.5	1.5	115	107	11 800	10 900	5 800	8 200	NU212EA	NJ	NUP
	110	28	1.5	1.5	155	157	15 800	16 000	5 200	7 300	NU2212EA	NJ	NUP
	130	31	2.1	2.1	177	157	18 000	16 000	4 900	7 000	NU312EA	NJ	NUP
	130	46	2.1	2.1	263	262	26 800	26 700	4 400	6 200	NU2312EA	NJ	NUP
65	120	23	1.5	1.5	127	119	13 000	12 100	5 400	7 600	NU213EA	NJ	NUP
	120	31	1.5	1.5	176	181	18 000	18 400	4 800	6 700	NU2213EA	NJ	NUP
	140	33	2.1	2.1	213	191	21 800	19 500	4 600	6 500	NU313EA	NJ	NUP
	140	48	2.1	2.1	293	287	29 800	29 300	4 100	5 800	NU2313EA	NJ	NUP
70	125	24	1.5	1.5	140	137	14 300	14 000	5 000	7 100	NU214EA	NJ	NUP
	125	31	1.5	1.5	184	194	18 800	19 800	4 500	6 200	NU2214EA	NJ	NUP
	150	35	2.1	2.1	242	222	24 700	22 600	4 200	6 000	NU314EA	NJ	NUP
	150	51	2.1	2.1	325	325	33 000	33 000	3 800	5 300	NU2314EA	NJ	NUP
75	130	25	1.5	1.5	154	156	15 700	16 000	4 700	6 600	NU215EA	NJ	NUP
	130	31	1.5	1.5	191	207	19 500	21 100	4 200	5 900	NU2215EA	NJ	NUP
	160	37	2.1	2.1	284	263	29 000	26 800	4 000	5 600	NU315EA	NJ	NUP
	160	55	2.1	2.1	390	395	39 500	40 000	3 500	4 900	NU2315EA	NJ	NUP
80	140	26	2	2	165	167	16 800	17 000	4 400	6 100	NU216EA	NJ	NUP
	140	33	2	2	220	243	22 500	24 800	3 900	5 500	NU2216EA	NJ	NUP
85	150	28	2	2	198	199	20 100	20 300	4 100	5 800	NU217EA	NJ	NUP
	150	36	2	2	257	279	26 200	28 400	3 700	5 200	NU2217EA	NJ	NUP
90	160	30	2	2	215	217	21 900	22 200	3 900	5 500	NU218EA	NJ	NUP
	160	40	2	2	286	315	29 200	32 000	3 500	4 900	NU2218EA	NJ	NUP
95	170	32	2.1	2.1	260	265	26 600	27 000	3 600	5 200	NU219EA	NJ	NUP

Note 1) Minimum allowable dimension for chamfer dimension *r* or *r*₁. 2) The value for standard type cage 3) The value for NU type

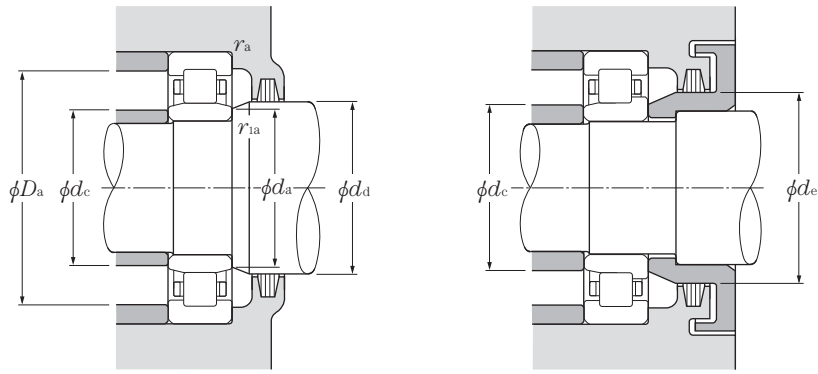

Dynamic equivalent radial load
 $P_r = F_r$

Static equivalent radial load
 $P_{0r} = F_r$

Dimensions		Abutment and fillet dimensions							Mass ³⁾
mm		d_a min	d_c max	$d_{\dot{a}}$ min	mm d_e min	D_a max	r_{as} max	r_{las} max	kg (approx.)
F_W	J								
26.5	29.5	24	26	29	32	42	1	0.6	0.115
26.5	29.5	24	26	29	32	42	1	0.6	0.146
27.5	31.1	24	27	30	33	45.5	1	0.6	0.176
27.5	31.1	24	27	30	33	45.5	1	0.6	0.242
31.5	34.5	29	31	34	37	47	1	0.6	0.151
31.5	34.5	29	31	34	37	47	1	0.6	0.186
34	38	31.5	33	37	40	55.5	1	1	0.275
34	38	31.5	33	37	40	55.5	1	1	0.386
37.5	41.1	34	37	40	44	57	1	0.6	0.226
37.5	41.1	34	37	40	44	57	1	0.6	0.297
40.5	44.9	36.5	40	44	48	65.5	1	1	0.398
40.5	44.9	36.5	40	44	48	65.5	1	1	0.58
44	48	39	43	46	50	65.5	1	0.6	0.327
44	48	39	43	46	50	65.5	1	0.6	0.455
46.2	51	41.5	45	48	53	72	1.5	1	0.545
46.2	51	41.5	45	48	53	72	1.5	1	0.78
49.5	53.9	46.5	49	52	56	73.5	1	1	0.426
49.5	53.9	46.5	49	52	56	73.5	1	1	0.552
52	57.6	48	51	55	60	82	1.5	1.5	0.754
52	57.6	48	51	55	60	82	1.5	1.5	1.06
54.5	58.9	51.5	54	57	61	78.5	1	1	0.495
54.5	58.9	51.5	54	57	61	78.5	1	1	0.6
58.5	64.5	53	57	60	66	92	1.5	1.5	0.996
58.5	64.5	53	57	60	66	92	1.5	1.5	1.41
59.5	63.9	56.5	58	62	67	83.5	1	1	0.503
59.5	63.9	56.5	58	62	67	83.5	1	1	0.587
65	71.4	59	63	67	73	101	2	2	1.3
65	71.4	59	63	67	73	101	2	2	1.9
66	70.8	61.5	65	68	73	92	1.5	1	0.675
66	70.8	61.5	65	68	73	92	1.5	1	0.807
70.5	77.7	64	69	72	80	111	2	2	1.65
70.5	77.7	64	69	72	80	111	2	2	2.37
72	77.6	68	71	75	80	102	1.5	1.5	0.923
72	77.6	68	71	75	80	102	1.5	1.5	1.21
77	84.6	71	75	79	86	119	2	2	2.05
77	84.6	71	75	79	86	119	2	2	2.96
78.5	84.5	73	77	81	87	112	1.5	1.5	1.21
78.5	84.5	73	77	81	87	112	1.5	1.5	1.6
82.5	91	76	81	85	93	129	2	2	2.54
82.5	91	76	81	85	93	129	2	2	3.48
83.5	89.5	78	82	86	92	117	1.5	1.5	1.3
83.5	89.5	78	82	86	92	117	1.5	1.5	1.7
89	98	81	87	92	100	139	2	2	3.1
89	98	81	87	92	100	139	2	2	4.25
88.5	94.5	83	87	90	96	122	1.5	1.5	1.41
88.5	94.5	83	87	90	96	122	1.5	1.5	1.79
95	104.6	86	93	97	106	149	2	2	3.74
95	104.6	86	93	97	106	149	2	2	5.25
95.3	101.7	89	94	97	104	131	2	2	1.67
95.3	101.7	89	94	97	104	131	2	2	2.12
100.5	107.7	94	99	104	110	141	2	2	2.11
100.5	107.7	94	99	104	110	141	2	2	2.68
107	114.6	99	105	109	116	151	2	2	2.44
107	114.6	99	105	109	116	151	2	2	3.33
112.5	121	106	111	116	123	159	2	2	3.02